

ELECTRIC TOOL PARTS LIST

■ **COMPOUND SAW**
Model C 10FCE2

2006 · 10 · 11
(E1)

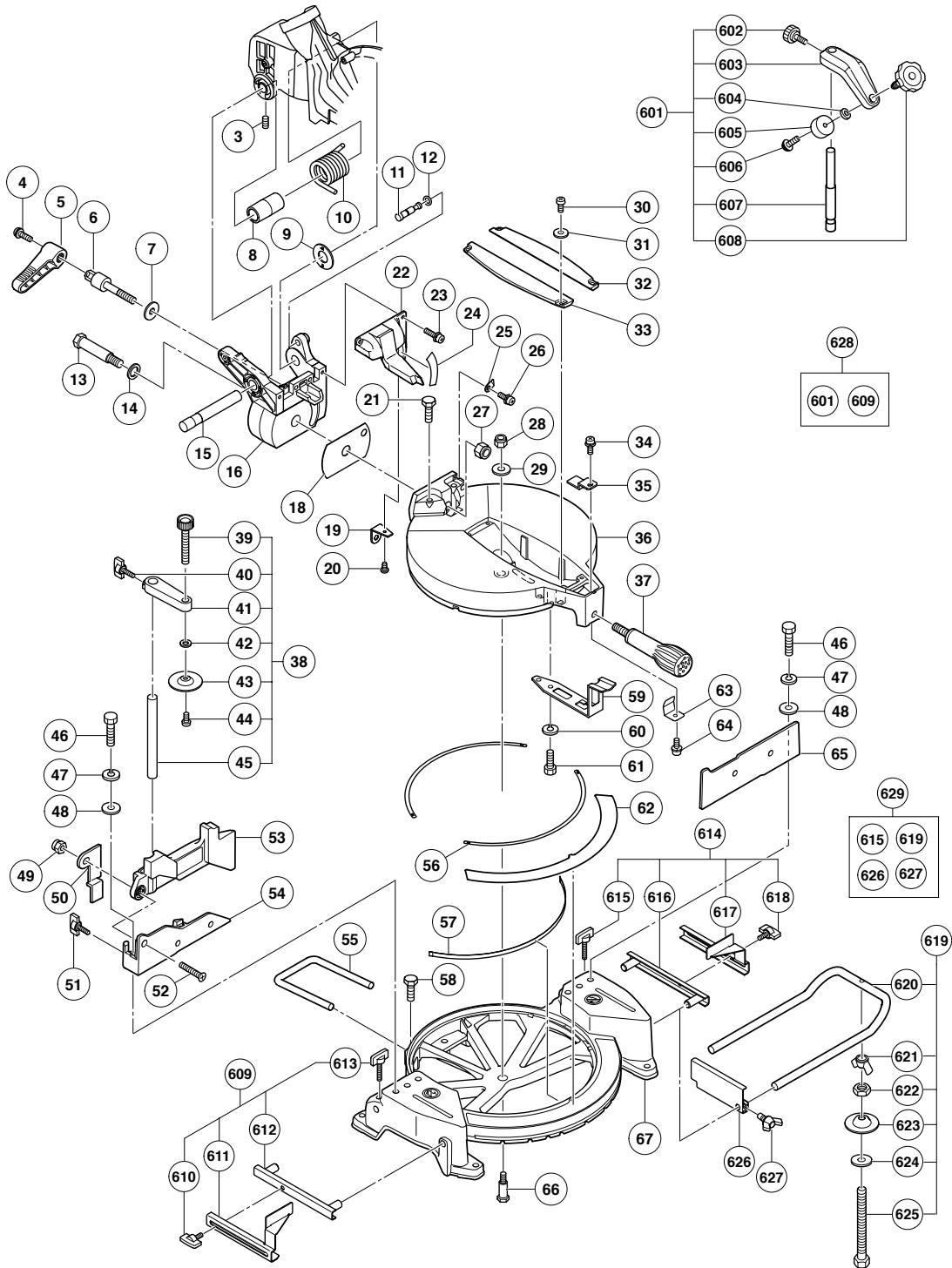

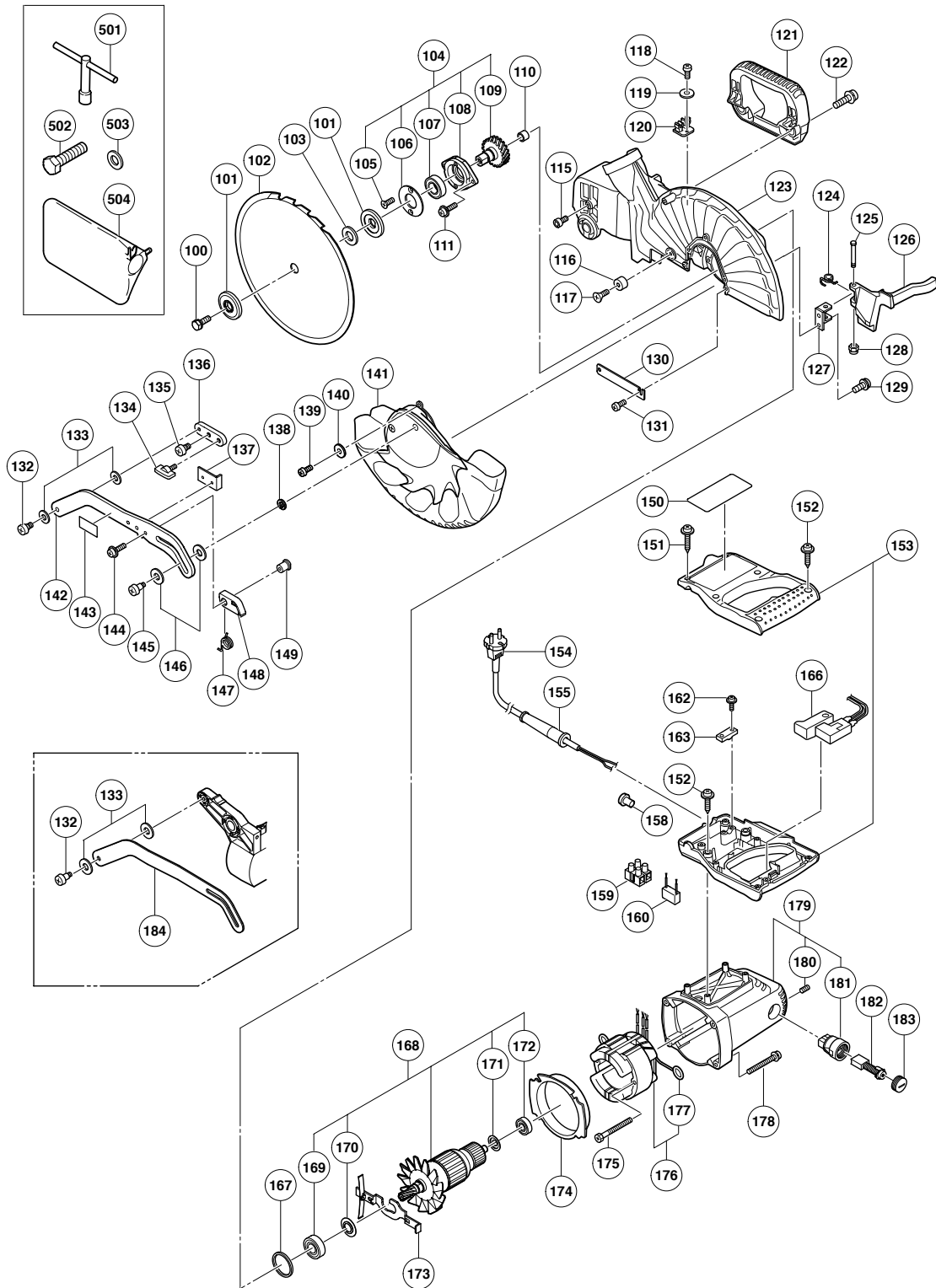

PARTS

C 10FCE2

ITEM NO.	CODE NO.	DESCRIPTION	NO. USED	REMARKS
3	307-956	SEAL LOCK HEX. SOCKET SET SCREW M6X10	1	
4	323-208	MACHINE SCREW (W/WASHERS) M6X20 (BLACK)	1	
5	322-935	CLAMP LEVER	1	
6	326-706	BOLT (LEFT HAND) M10	1	
7	318-934	SPECIAL WASHER	1	
8	322-889	SLEEVE	1	
9	322-965	LINER (D)	1	
10	322-890	SPRING	1	
11	302-518	STOPPER PIN ASS'Y	1	INCLUD. 12
12	984-528	O-RING (P-6)	1	
13	322-933	SHAFT (D)	1	
14	322-934	WASHER M16	1	
15	322-888	SHAFT (C)	1	
16	322-932	HINGE	1	
18	322-937	LINER (B)	1	
19	322-963	DUST GUIDE HOLDER	1	
20	949-215	MACHINE SCREW M4X8 (10 PCS.)	1	
21	303-409	NYLOCK BOLT M8X25	2	
22	322-891	DUST GUIDE ASS'Y	1	INCLUD. 19, 20, 24
23	987-512	MACHINE SCREW (W/SP. WASHER) M5X16	2	
24	322-892	SCALE (B)	1	
25	322-893	INDICATOR (B)	1	
26	304-043	MACHINE SCREW (W/WASHERS) M4X10 (BLACK)	1	
27	680-418	NYLON NUT M12	1	
28	975-348	NYLON NUT M8	1	
29	318-929	WASHER (F)	1	
30	949-217	MACHINE SCREW M4X12 (10 PCS.)	4	
31	949-429	BOLT WASHER M4 (10 PCS.)	4	
32	322-930	TABLE INSERT (B)	1	
33	322-929	TABLE INSERT (A)	1	
34	304-043	MACHINE SCREW (W/WASHERS) M4X10 (BLACK)	1	
35	322-904	INDICATOR (A)	1	
36	326-695	TURN TABLE	1	
37	322-898	SIDE HANDLE	1	
38	322-952	WISE ASS'Y	1	INCLUD. 39-45
39	302-522	KNOB BOLT M10X66	1	
40	301-806	WING BOLT M6X15	1	
41		SCREW HOLDER	1	
42	949-432	BOLT WASHER M6 (10 PCS.)	1	
43	302-532	WISE PLATE	1	
44	949-216	MACHINE SCREW M4X10 (10 PCS.)	1	
45	322-954	WISE SHAFT	1	
46	949-678	BOLT M8X35 (10 PCS.)	4	
47	949-457	SPRING WASHER M8 (10 PCS.)	4	
48	949-433	BOLT WASHER M8 (10 PCS.)	4	
49	963-837	NYLON NUT M6	1	
50	326-711	PLATE (A)	1	
51	301-806	WING BOLT M6X15	1	
52	949-342	FLAT HD. SCREW M6X25 (10 PCS.)	1	
53	326-704	SUB FENCE (B)	1	
54	326-698	FENCE (B)	1	

PARTS

C 10FCE2

ITEM NO.	CODE NO.	DESCRIPTION	NO. USED	REMARKS
55	326-705	HOLDER	1	
56	322-901	LINER (A)	2	
57	322-964	LINER (C)	1	
58	949-611	BOLT M6X12 (10 PCS.)	1	
59	322-903	SPRING PLATE	1	
60	949-457	SPRING WASHER M8 (10 PCS.)	2	
61	949-655	HEX. SOCKET HD. BOLT M8X16 (10 PCS.)	2	
62	326-826	SCALE (A)	1	
63	326-696	SPACER (A)	1	
64	317-200	MACHINE SCREW (W/WASHERS) M4X8 (BLACK)	1	
65	326-697	FENCE (A)	1	
66	322-902	SHAFT (B)	1	
67	326-694	BASE ASS'Y	1	INCLUD. 62
100	998-335	BOLT (LEFT HAND) W/WASHER M7X17.5	1	
* 101	308-789	WASHER (D)	2	EXCEPT FOR EUROPE, CHN
* 101	318-961	WASHER (A)	1	FOR EUROPE, CHN
* 101	318-962	WASHER (B)	1	FOR EUROPE, CHN
* 102	319-107	TCT SAW BLADE 255MM-D30 HOLE-NT30	1	
* 102	319-106	TCT SAW BLADE 255MM-D25.4 HOLE-NT24	1	
* 102	318-963	TCT SAW BLADE 255MM-D15.88 HOLE-NT24	1	
* 102	318-964	TCT SAW BLADE 255MM-D25.4 HOLE-NT100	1	
* 103	974-663Z	COLLAR (A) FOR D30 HOLE	1	FOR EUROPE
* 103	976-819	COLLAR (B) FOR D25.4 HOLE	1	FOR AUS, INA, MAL, SIN, SYR, THA, CHN
104	323-133	SPINDLE ASS'Y	1	INCLUD. 105-109
105	990-430	SEAL LOCK FLAT HD. SCREW M4X10	2	
106	322-919	BEARING COVER	1	
107	600-3VV	BALL BEARING 6003VVCMP2L	1	
108	322-918	BEARING HOLDER	1	
109	322-917	SPINDLE AND GEAR SET	1	
110	982-027	NEEDLE BEARING (HK1010)	1	
111	987-512	MACHINE SCREW (W/SP. WASHER) M5X16	2	
115	949-819	HEX. SOCKET HD. BOLT M5X10 (10 PCS.)	1	
116	961-729	CUSHION	1	
117	949-340	FLAT HD. SCREW M6X16 (10 PCS.)	1	
118	949-217	MACHINE SCREW M4X12 (10 PCS.)	1	
119	949-429	BOLT WASHER M4 (10 PCS.)	1	
120	322-920	HOOK	1	
121	326-708	HANDLE	1	
122	323-208	MACHINE SCREW (W/WASHERS) M6X20 (BLACK)	2	
* 123	326-701	GEAR CASE	1	INCLUD. 110
* 123	326-702	GEAR CASE	1	INCLUD. 110 FOR EUROPE
* 124	323-987	LEVER SPRING	1	FOR EUROPE
* 125	323-990	LEVER SHAFT	1	FOR EUROPE
* 126	323-979	LOCK LEVER (C)	1	FOR EUROPE
* 127	323-982	LEVER HOLDER	1	FOR EUROPE
* 128	877-371	NYLON NUT M5	1	FOR EUROPE
* 129	949-236	MACHINE SCREW M5X10 (10 PCS.)	2	FOR EUROPE
* 130	322-951	SPINDLE COVER	1	FOR EUROPE, USA, CAN, AUS, MAL
* 131	949-215	MACHINE SCREW M4X8 (10 PCS.)	2	FOR EUROPE, USA, CAN, AUS, MAL
132	322-950	SPECIAL SCREW M6	1	
133	322-948	WASHER M7	2	

PARTS

C 10FCE2

ITEM NO.	CODE NO.	DESCRIPTION	NO. USED	REMARKS	
* 134	301-806	WING BOLT M6X15	1	FOR EUROPE	
* 135	322-950	SPECIAL SCREW M6	1	FOR EUROPE	
* 136	323-986	TURN PLATE	1	FOR EUROPE	
* 137	323-985	STOP PLATE	1	FOR EUROPE	
	138	949-454	SPRING WASHER M5 (10 PCS.)	1	
	139	949-215	MACHINE SCREW M4X8 (10 PCS.)	3	
	140	949-429	BOLT WASHER M4 (10 PCS.)	3	
	141	326-707	PROTECTIVE COVER	1	
* 142	323-980	LINK (A) ASS'Y	1	INCLUD. 132, 133, 136, 137, 143, 144, 147-149 FOR EUROPE	
* 143		CAUTION LABEL (F)	1	FOR EUROPE	
* 144	935-196	MACHINE SCREW (W/WASHERS) M4X12 (BLACK)	3	FOR EUROPE	
	145	322-947	SPECIAL SCREW (C) M5	1	
	146	322-938	WASHER M10	2	
* 147	323-984	RETURN SPRING (A)	1	FOR EUROPE	
* 148	323-989	RETURN PLATE	1	FOR EUROPE	
* 149	323-988	RETURN SHAFT	1	FOR EUROPE	
	150		NAME PLATE	1	
	151	307-028	TAPPING SCREW (W/FLANGE) D4X25 (BLACK)	2	
	152	301-653	TAPPING SCREW (W/FLANGE) D4X20 (BLACK)	6	
	153	326-703	SWITCH HANDLE	1	
* 154	500-234Z	CORD	1		
* 154	500-468Z	CORD	1	FOR THA	
* 154	500-447Z	CORD	1	FOR SYR	
* 154	500-423Z	CORD	1	FOR MAL, SIN	
* 154	500-453Z	CORD	1	FOR USA, CAN	
* 154	500-435Z	CORD	1	FOR GBR (230V)	
* 154	500-461Z	CORD	1	FOR GBR (110V)	
* 154	500-439Z	CORD	1	FOR AUS	
* 154	500-456Z	CORD	1	FOR CHN	
	155	940-778	CORD ARMOR D10.7	1	
* 158	959-141	CONNECTOR 50092 (10 PCS.)	2	FOR USA, CAN	
* 159	958-308Z	PILLAR TERMINAL (A)	1	EXCEPT FOR USA, CAN	
* 160	326-709	NOISE SUPPRESSOR	1	FOR AUS, AUT, EUROPE, INA, GBR (230V), TUR	
* 160	326-710	NOISE SUPPRESSOR	1	FOR GBR (110V)	
	162	984-750	TAPPING SCREW (W/FLANGE) D4X16	2	
	163	937-631	CORD CLIP	1	
* 166	326-700	SWITCH (3P FASTON TYPE) W/O LOCK	1		
* 166	326-699	SWITCH (3P FASTON TYPE) W/O LOCK	1	FOR USA, CAN	
	167	303-792	RUBBER RING	1	
* 168	360-656U	ARMATURE ASS'Y 110V-120V	1	INCLUD. 169-172	
* 168	360-695E	ARMATURE ASS'Y 220V-230V	1	INCLUD. 169-172	
* 168	360-695F	ARMATURE ASS'Y 240V	1	INCLUD. 169-172	
	169	620-2VV	BALL BEARING 6202VVCMP2L	1	
	170	980-700	DUST WASHER (B)	1	
	171	302-428	WASHER (A)	1	
	172	600-0VV	BALL BEARING 6000VVCMP2L	1	
	173	322-916	LOCK LEVER	1	
	174	322-915	FAN GUIDE	1	
	175	953-121	HEX. HD. TAPPING SCREW D5X50	2	
* 176	340-686D	STATOR ASS'Y 110V	1	INCLUD. 177	

PARTS

ITEM NO.	CODE NO.	DESCRIPTION	NO. USED	REMARKS		
*	176	340-686C	STATOR ASS'Y 120V	1	INCLUD. 177	
*	176	340-687E	STATOR ASS'Y (B) 220V-230V	1	INCLUD. 177	
*	176	340-686E	STATOR ASS'Y 220V	1	INCLUD. 177 FOR CHN	
*	176	340-687F	STATOR ASS'Y (B) 240V	1	INCLUD. 177	
	177	937-623	BRUSH TERMINAL	2		
	178	322-123	MACHINE SCREW (W/WASHERS) M5X40 (BLACK)	4		
	179	322-914	HOUSING ASS'Y	1	INCLUD. 180, 181	
	180	938-477	HEX. SOCKET SET SCREW M5X8	2		
	181	938-241	BRUSH HOLDER	2		
*	182	999-038	CARBON BRUSH (1 PAIR)	2	FOR 110V-120V	
*	182	999-065	CARBON BRUSH (1 PAIR)	2	FOR 220V-240V	
	183	945-161	BRUSH CAP	2		
*	184	322-949	LINK	1		

STANDARD ACCESSORIES

C 10FCE2

ITEM NO.	CODE NO.	DESCRIPTION	NO. USED	REMARKS
501	940-543	BOX WRENCH 10MM	1	
502	949-695	BOLT M10X35 (10 PCS.)	1	
* 503	974-663Z	COLLAR (A) FOR D30 HOLE	1	FOR AUS
504	322-955	DUST BAG (BLACK)	1	

OPTIONAL ACCESSORIES

ITEM NO.	CODE NO.	DESCRIPTION	NO. USED	REMARKS
601	322-957	VICE (B) ASS'Y	1	INCLUD. 602-608
602	998-836	KNOB BOLT M6X11	1	
603		SCREW HOLDER (B)	1	
604	306-985	WASHER (H)	1	
605	964-851	BASE RUBBER	1	
606	304-043	MACHINE SCREW (W/WASHERS) M4X10 (BLACK)	1	
607	318-967	VICE SHAFT	1	
608	321-551	KNOB BOLT M10X54	1	
609	322-713	CROWN MOLDING STOPPER (L) ASS'Y	1	INCLUD. 610-613
610	301-806	WING BOLT M6X15	1	
611		CROWN MOLDING STOPPER (L)	1	
612	321-390	CROWN MOLDING STOPPER HOLDER	1	
613	316-030	WING BOLT M6X52	1	
614	322-714	CROWN MOLDING STOPPER (R) ASS'Y	1	INCLUD. 615-618
615	316-030	WING BOLT M6X52	2	
616	321-390	CROWN MOLDING STOPPER HOLDER	1	
617		CROWN MOLDING STOPPER (R)	1	
618	301-806	WING BOLT M6X15	1	
619	322-956	HOLDER ASS'Y	1	INCLUD. 620-625
620	321-549	HOLDER	1	
621	949-313	WING NUT M6 (10 PCS.)	1	
622	949-556	NUT M6 (10 PCS.)	1	
623	322-047	VICE PLATE	1	
624	949-425	WASHER M6 (10 PCS.)	1	
625	323-134	HIGH TENSION BOLT M6X80	1	
626	974-561	STOPPER	1	
627	949-404	WING BOLT M6X20 (10 PCS.)	1	
628	322-712	CROWN MOLDING VISE ASS'Y	1	INCLUD. 601, 609
629	322-710	GUIDE ASS'Y	1	INCLUD. 615, 619, 626, 627
* 630	976-472	TCT SAW BLADE CROSS-CUT 255MM-D15.9 HOLE	1	FOR USA, CAN
* 631	319-658	TCT SAW BLADE 255MM-D15.88 HOLE-NT100	1	FOR USA, CAN

